

(No Model.)

2 Sheets—Sheet 1.

W. COPLEY & H. E. HODGSON.  
STRAIGHTENING MACHINE FOR SHAFTING.

No. 525,003.

Patented Aug. 28, 1894.

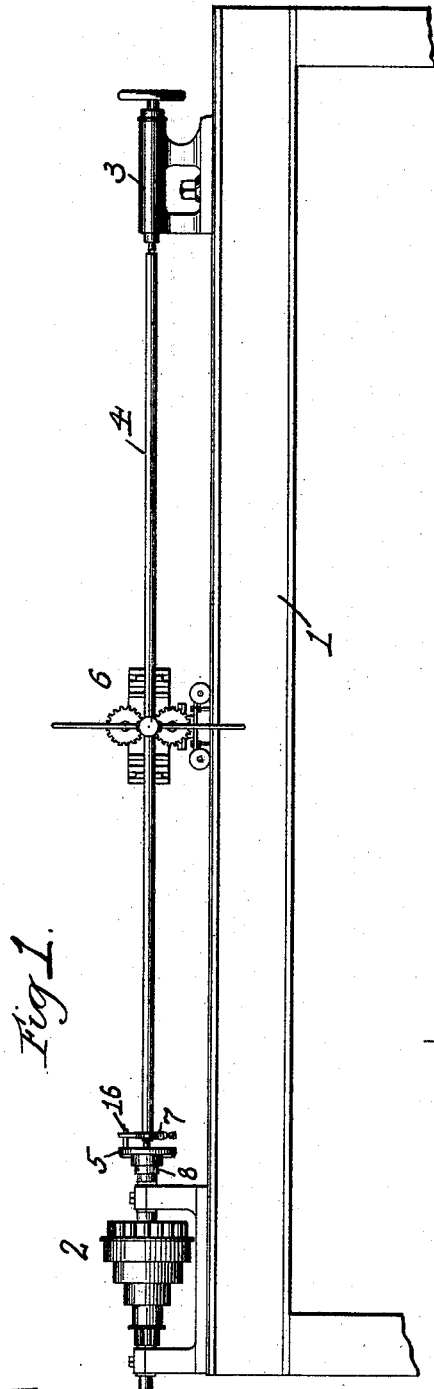

Fig. 1.

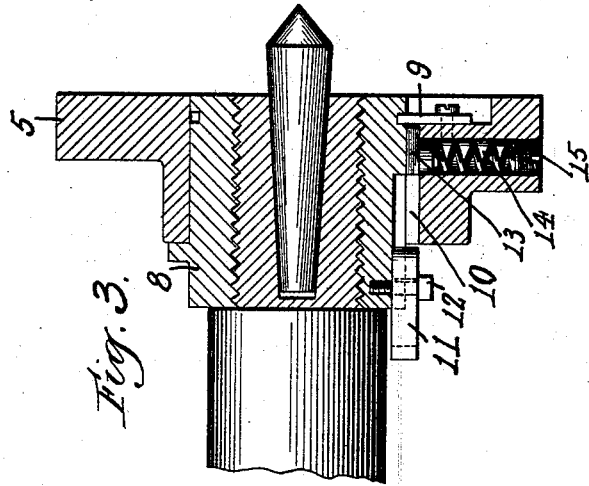

Fig. 3.

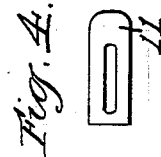

Fig. 4.

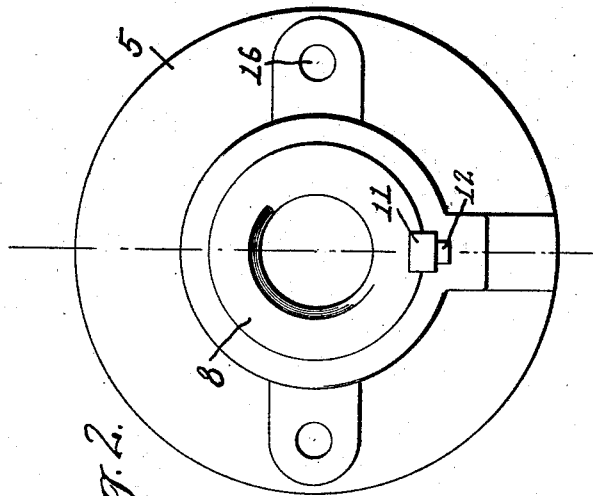

Fig. 2.

Witnesses  
Wm. L. Fleming  
J. M. Pheasant

William Copley  
Henry Edwin Hodgson Inventors

by James M. See  
Atty

(No Model.)

2 Sheets—Sheet 2.

W. COPLEY & H. E. HODGSON.  
STRAIGHTENING MACHINE FOR SHAFTING.

No. 525,003.

Patented Aug. 28, 1894.

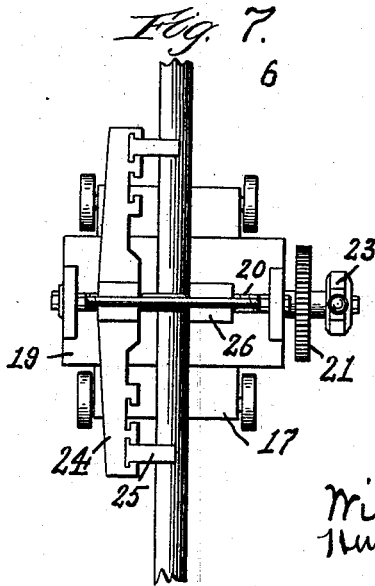
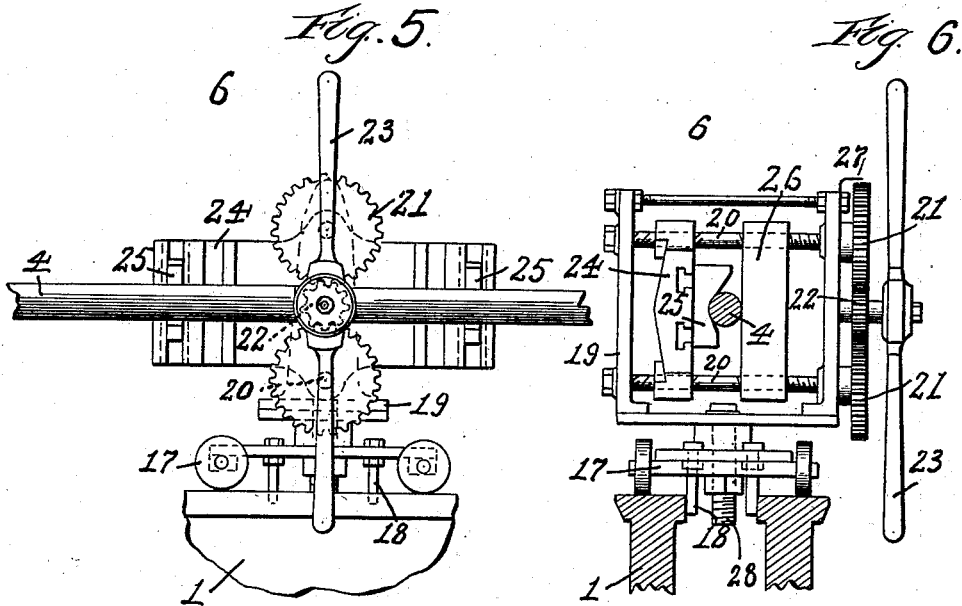

Witnesses:  
 Wm. J. Fleming -  
 H. B. Baheem.

William Copley  
 Henry Edwin Hodgson  
 Inventors.

By James M. See  
 Atty.

# UNITED STATES PATENT OFFICE.

WILLIAM COPLEY, OF HALIFAX, AND HENRY EDWIN HODGSON, OF CLECKHEATON, ENGLAND.

## STRAIGHTENING-MACHINE FOR SHAFTING.

SPECIFICATION forming part of Letters Patent No. 525,003, dated August 28, 1894.

Application filed February 15, 1894. Serial No. 500,317. (No model.) Patented in England September 11, 1891, No. 15,405, and April 21, 1892, No. 7,526.

### *To all whom it may concern:*

Be it known that we, WILLIAM COPLEY, residing at Halifax, and HENRY EDWIN HODGSON, residing at Cleckheaton, county of York, England, subjects of the Queen of Great Britain, have invented certain new and useful Improvements in Straightening-Machines for Shafting, (patented in Great Britain September 11, 1891, No. 15,405, and April 21, 1892, No. 7,526,) of which the following is a specification.

This invention pertains to improvements in machines for straightening bar iron preparatory to turning the same to form shafting, the machine being of course also useful in straightening rough or turned bars designed for other purposes. The machine involves first, a lathe-like machine for supporting and rotating the bar for the detection of the crooks, the rotating force being yieldingly applied so that the bar may be stopped at any time by the operation of the straightening press or by the operator's hand; and second, a straightening press adjustable along the length of the bar.

The improvements will be readily understood from the following description taken in connection with the accompanying drawings, in which—

Figure 1, is a front elevation of a machine embodying our improvements; Fig. 2, an elevation of the rear face of the driving apparatus through which rotary motion is transmitted to the bar; Fig. 3, a vertical diametrical section of this driving apparatus; Fig. 4, a plan of the locking-key to be employed for positive driving of the bar; Fig. 5, a front view of the straightening press; Fig. 6, a side view of the straightening press the back-piece in this view being shown as provided with horizontal jaw-holding slots, and Fig. 7, a plan of the straightening press.

In the drawings:—1, indicates the bed of the machine, similar in all general respects to the bed of a lathe; 2, the head-stock thereof, similar to a lathe; 3, the tail-stock, adjustable along the bed to suit the length of bar to be dealt with; 4, the bar to be straightened; 5, the face-plate secured upon the nose of the head-stock spindle in the peculiar

manner hereinafter indicated; 6, the straightening press arranged to travel along the bed of the machine and operate upon any part of the length of the bar to be straightened; 7, a lathe-dog fast upon the head-stock end of the bar to be straightened; 8, a hub screwed upon the nose of the head-stock spindle, the face-plate 5 turning freely upon this hub; 9, a clip secured to the face-plate 5 and engaging its inner end in a circumferential groove in hub 8, whereby the face-plate is prevented from endwise motion upon the hub, the clip being removably attached to the face-plate by a screw as shown so that the face-plate may be readily detached from the hub; 10, a key-way half in the hub 8 and half in the bore of the face-plate; 11, a slotted key secured by a screw in the key-way of hub 8 and adapted for endwise adjustment so as to be free from the key-way in the face-plate, as seen in Fig. 3, or to be projected forward so as to engage the key-way of the face-plate and lock the face-plate positively to the hub 8; 12, the screw securing the key in the key-way of the hub and, by means of a slot in the key, permitting the endwise adjustment of the key; 13, a friction-pad seated in a forward prolongation of the key-way 10 in the face-plate forward of the end of the key-way in the hub 8, the inner surface of this pad therefore bearing frictionally upon the smooth periphery of hub 8 within the bore of the face-plate; 14, a spring seated in a radial recess in the face-plate and pressing inwardly upon the friction-pad; 15, a screw in the face-plate bearing against the outer end of the spring and furnishing an adjustable abutment for the spring, whereby the frictional pressure of the pad against hub 8 may be adjusted; 16, the usual driving stud secured in the face-plate and projecting outwardly to engage the tail of dog 7 in case a dog with a straight tail is employed; 17, a trolley arranged to run along the ways of the machine; 18, studs projecting from the trolley downward between the ways of the machine bed to prevent sidewise displacement of the trolley; 19, a rectangular frame carried by the trolley in such position that the bar to be straightened will pass about cen-

trally through the open frame; 20, two screws arranged one above and the other below the axis of bar 4, these two screws being journaled in the frame 19 and each being provided with right and left hand threads; 21, gears fast upon the front ends of the screws; 22, a pinion engaging both these gears and journaled on the frame; 23, a lever fast with the pinion 22, whereby the turning of the lever causes the two screws to rotate in unison; 24, a back-piece of considerable length disposed within the frame to the rear of bar 4 and having ears threaded upon the rear portions of screws 20; 25, V-shaped die-blocks secured in the front face of back-piece 24 near the ends thereof, being held thereto by flanges engaging vertical T-shaped slots in the back-piece; 26, a front die threaded upon the forward portion of the two screws 20 and disposed vertically in front of bar 4 and midway between the die-blocks 25; 27, a fixed pointer near one of the gears; and 28, a screw uniting the press-frame to the trolley and serving also as means by which the press-frame may be adjusted vertically to suit the height of centers of different lathes.

The head-stock spindle will turn face-plate 5 with a force corresponding with the friction arising from the pressure of pad 13 and the spring should be so adjusted in strength that the bar will not be driven with so much force that the operator cannot readily arrest the motion of the bar by holding it with his hand.

If lever 23 be turned in one direction the rear die-blocks will move rearwardly and the front die-block will move forwardly, thus becoming entirely free from the shaft in its rotation. If the lever be turned in the other direction the die-blocks will forcibly approach the bar 4 and subject it to bending strain at the point between the V-shaped dies.

In using the machine the bar to be straightened is centered and provided with a dog and put into the machine and the head-stock spindle started into rotation, and the rotation of the head-stock spindle is not stopped till the work is complete. While the bar is rotating the high or outwardly crooked parts of the bar are detected and marked in the usual manner. The rotation of the bar is then arrested by the pressure of the machine or the operator's hand upon it and, while the bar is thus held, with a marked high place to the front, the straightening press is brought to the marked point with the front die 26 to the mark. The lever is then turned to move the dies and straighten the crook according to judgment, after which other crooks are dealt with in the same manner. The pressure is then released, thus allowing the bar to again turn for the testing of the work and the detection of further crooks.

The operator, upon applying the screw-pressure, chalks the gear at pointer 27, and when the first bend has been straightened the last chalk mark will indicate the proper

pressure to be applied at all future bends. The chalking of the bends may be avoided by gently applying the pressure of the dies which will cause the shaft to come to rest with the high part of the bend opposite the central die. The back dies, 25, are preferably arranged to slide freely in their slots in the back piece 24 so as to rise and fall with the bends as the pressure is being gently applied. The outreach of the back-dies 25 may be increased so as to reach in between cranks in case the machine is to be used for straightening such articles as loom cranks, and in such case the back-dies should be held in horizontal slots in the back piece 24 (as indicated in Fig. 6) and have no vertical motion.

We claim as our invention—

1. In a bar straightening machine, the combination, substantially as set forth, of a bed, a head-stock and tail-stock thereon, a straightening press adapted to traverse the bed, a face-plate carried by the head-stock spindle, a friction-pad arranged to transmit rotary motion from the head-stock spindle to the face-plate, and an adjustable spring for regulating the driving force of the friction-pad.

2. In a bar straightening machine, the combination, substantially as set forth, of a bed, a head-stock and tail-stock thereon, a straightening press adapted to traverse the bed, a hub screwed upon the nose of the head-stock spindle, a face-plate fitted to rotate upon said nose, a friction-pad carried by the face-plate and bearing upon the periphery of said hub, a spring pressing inwardly upon said friction-pad, and an adjusting screw for regulating the pressure of the spring.

3. In a bar straightening machine, the combination, substantially as set forth, of a bed, a head-stock and tail-stock thereon, a straightening press adapted to traverse the bed, a hub screwed upon the nose of the head-stock spindle and provided with a circumferential groove, a face-plate fitted for rotation upon said hub, a clip carried by the face-plate and engaging the groove of the hub, a friction-pad carried by the face-plate and engaging the periphery of the hub, and a spring pressing upon said friction-pad.

4. In a bar straightening machine, the combination, substantially as set forth, of a bed, a head-stock and tail-stock thereon, a straightening press adapted to traverse the bed, a hub screwed upon the nose of the head-stock spindle and provided with a key-way, a face-plate fitted to rotate upon said hub and provided with a key-way, a sliding key arranged to engage said two key-ways and lock the face-plate to the hub, and a friction-pad and spring locking the face-plate yieldingly to the hub.

5. In a bar straightening machine, the combination, substantially as set forth, of a bed, a head-stock and tail-stock carried thereby, a face-plate carried by the head-stock spindle, a trolley adapted to traverse the bed, a frame supported by the trolley, a pair of back-dies supported by the frame, a front die supported

by the frame in a vertical plane between the back-dies, and screws geared together and connected with the frame and dies and arranged to move the dies in unison.

5 6. In a bar straightening machine, the combination, substantially as set forth, of a bed, a head-stock and tail-stock thereon, a face-plate carried by the head-stock spindle, a frame fitted to be traversed along the bed, a  
10 pair of united dies carried by the frame, an opposing die carried by the frame in a verti-

cal plane between the first mentioned dies, and mechanism connected with the frame and dies and arranged to simultaneously move the single die and the pair of dies equally in  
15 opposite directions.

WILLIAM COPLEY.

HENRY EDWIN HODGSON.

Witnesses:

B. J. WAKEMAN,

B. POLLARD.